



Washer extractors

W4130N, W4180N, W4250N

Features and benefits

- Frequency-controlled motor with fixed wash and extraction speeds ensures smooth action in the wash and extraction sequence
- Solid mount construction with robust frame in galvanized steel
- Extremely low water and energy consumption – see table below
- Program control:
 - Compass Control® with:**
 - Large display and one dial for easy program selection
 - Language selection
 - Two Quick Start buttons for frequently used wash programs
 - Wash program packages optimized on *Economy*, *Performance* and *Time*
- Four compartment soap box for manual dosing of powder or liquid detergent
- Large door opening for easy loading/unloading
- Stainless and galvanized steel in all vital parts for high degree of rust protection
- SuperBalance™ guarantees the correct extraction force



Images shown are a representation of the product only and variations may occur.

Main options

- Automatic liquid detergent supply (optional I/O board)
- Stainless steel front panel
- Stainless steel side panels (only for Farm version)
- Connection of coin meter

Main specifications				W4130N		W4180N		W4250N	
Max. capacity		kg/lb		14/30		20/45		28/62	
Drum, volume		litre		130		180		250	
	diameter	ø mm		595		650		725	
Extraction		rpm		548		525		497	
G-factor				100		100		100	
Heating alternatives, 230/400V	electricity	kW		7.3/9.6		12.5		17.2	
	steam			x		x		x	
	non-heated			x		x		x	
Consumption data "Normal 60°C" * (3G01)				El	Steam	El	Steam	El	Steam
Total time		min		49	**	50	**	48	**
Water consumption (cold+hot)		litre		93+25	93+25	134+35	134+35	183+47	183+47
Energy consumption (motor/heating)		kWh		0.2/0.6	0.2	0.25/0.9	0.25	0.35/1.2	0.35
Steam consumption		kg		–	0.9	–	1.35	–	1.8

* Water temperature 15°C cold water and 65°C hot water.

** Depending on steam pressure.



Electrical connections*			W4130N	W4180N	W4250N
Heating	Voltage				
El.	230V 3AC 50 Hz	kW(A)	9.6(35)	12.5(50)	17.2(50)
	240V 3AC 60 Hz	kW(A)	9.6(35)	12.5(50)	17.2(50)
	400V 3N AC 50 Hz	kW(A)	9.6(16)	12.5(25)	17.2(35)
	440V 3AC 60 Hz	kW(A)	10.6(16)	13.8(25)	19.1(35)
Steam or non-heated	230V 1AC 50 Hz	kW(A)	1.4(10)	2.1(10)	2.8(16)
	240V 1AC 60 Hz	kW(A)	1.2(10)	2.3(10)	2.8(16)
Water and steam connection					
Water valves	DN		20	20	20
Water pressure	kPa		150-400	150-400	150-400
Capacity at 300 kPa	l/min		20	60	60
Drain valve	ø mm		75	75	75
Draining capacity	l/min		170	170	170
Steam valve	DN		15	15	15
Steam pressure	kPa		300-600	300-600	300-600
Liquid detergent supplies			5	5	5
Floor requirements					
Frequency of the dynamic force	Hz		9.1	8.8	8.3
Floor load at max extraction	kN		2.4 ± 3.1	2.9 ± 3.9	3.8 ± 4.9
Sound levels					
Sound pressure level**	dB(A)		70	64	68
Sound power level (IEC 60704-2-4)					
wash	dB(A)		66	67	66
extraction	dB(A)		69	69	72
Heat emission					
% of installed power, max			5	5	5
Shipping data					
Shipping volume	net, kg		175	228	287
	crated, kg		196	240	302
	m ³		0.91	1.18	1.51
Accessories					
Steel base frame			x	x	-
Hose kits for water or steam			x	x	x
Fluff collector			x	-	-
Dimensions in mm					
A	Width		720	750	830
B	Depth		790	880	955
C	Height		1200	1333	1410
D			365	435	495
E			830	915	990
F			910	1035	1120
G			45	45	45
H			1115	1245	1330
I			215	130	160
K			1095	1225	1290
L			130	215	245
M			910	1040	1125
N			420	325	325
O			-	295	335
P			100	100	100
R			235	225	265
1	Electrical connections	7	Control panel		
2	Cold water	8	Soap box		
3	Hot water	9	Connections for water re-use		
4	Steam connection	10	Door opening ø365 (W4130N) ø395 (W4180N) ø435, (W4250N)		
5	Drain				
6	Liquid supply connections				

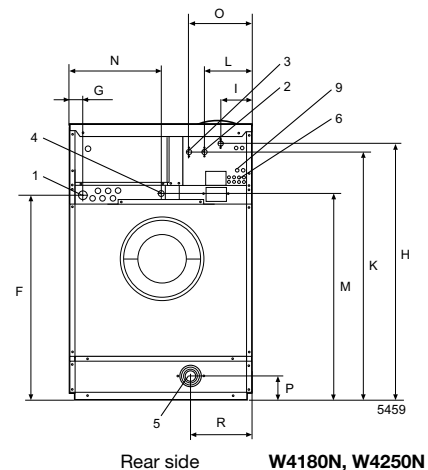
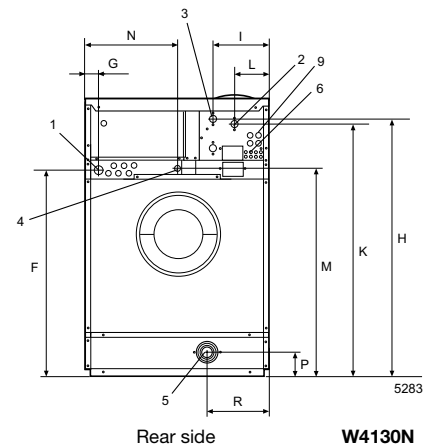
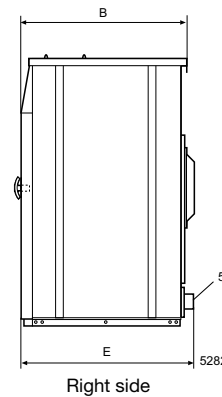
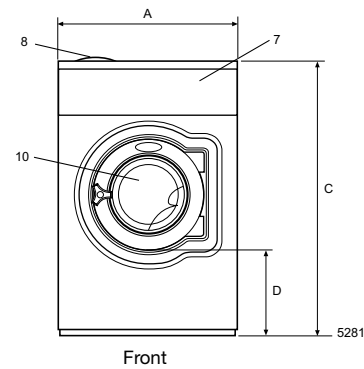

Front and side panels in light grey with "Blue Wave" on front panel (RAL 260 70 05, 250 60 30)

* Other voltages available, see installation manual

** Approx. value at operators position in a mid-size laundry room